



НЕРЖАВЕЮЩИЙ МЕТАЛЛОПРОКАТ

---

**ASTM A 350/A 350M – 04a**

# 30000

НАИМЕНОВАНИЙ ПРОДУКЦИИ



**Специальные  
Стали и Сплавы**



# 12

СОВРЕМЕННЫХ И АВТОМАТИЗИРОВАННЫХ  
СКЛАДОВ, ПЛОЩАДЬЮ БОЛЕЕ

# 50000 м<sup>2</sup>

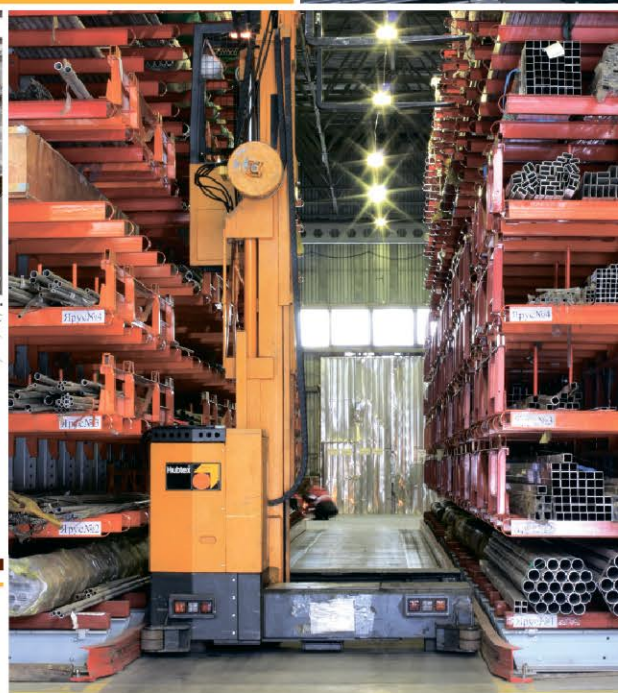

# 10000

**ТОНН**  
НЕСНИЖАЕМЫЙ  
СКЛАДСКОЙ ОСТАТОК

**Щелково**, +7 (495) 775-55-22  
ул. Заводская, д. 14Б, пом.17

**Челябинск**, +7 (351) 242-01-02  
пр-т Победы, д. 158, офис 407

**Санкт-Петербург**, +7 (812) 454-21-54  
пр-т Обуховской обороны, д. 112, литера И, БЦ "ВАНТ", офис 235

**Воронеж**, +7 (473) 300-38-88  
ул. Солнечная, 10Б, БК "Крепезж", офис 210

**Краснодар**, +7 (861) 205-00-10  
Ростовское шоссе, д. 14/2, офис 306

**Самара**, +7 (846) 300-44-54  
Заводское шоссе, д. 111, офис 452

**Нижний Новгород**, +7 (831) 260-12-22  
ул. Варварская, д. 32, литера Д, офис 301

**Пятигорск**, +7 (8793) 31-78-22  
Черкесское шоссе, д. 11





Designation: A 350/A 350M – 04a

## Standard Specification for Carbon and Low-Alloy Steel Forgings, Requiring Notch Toughness Testing for Piping Components<sup>1</sup>

This standard is issued under the fixed designation A 350/A 350M; the number immediately following the designation indicates the year of original adoption or, in the case of revision, the year of last revision. A number in parentheses indicates the year of last reapproval. A superscript epsilon (ε) indicates an editorial change since the last revision or reapproval.

*This standard has been approved for use by agencies of the Department of Defense.*

### 1. Scope\*

1.1 This specification<sup>2</sup> covers several grades of carbon and low-alloy steel forged or ring-rolled flanges, forged fittings and valves intended primarily for low-temperature service and requiring notch toughness testing. They are made to specified dimensions, or to dimensional standards, such as the ASME and API Specifications referenced in Section 2. Although this specification covers some piping components machined from rolled bar and seamless tubular materials (see 5.3.3), it does not cover raw material produced in these product forms.

1.2 No limitation on size is intended beyond the ability of the manufacturer to obtain the specified requirements. However, Class 3 of Grade LF787 is only available in the quenched-and-precipitation heat treated condition.

1.3 Supplementary requirements are provided for use when additional testing or inspection is desired. These shall apply only when specified by the purchaser in the order.

1.4 This specification is expressed in both inch-pound units and in SI units. However, unless the order specifies the applicable “M” specification designation (SI units), the material shall be furnished to inch-pound units.

1.5 The values stated in either inch-pound units or SI units are to be regarded separately as standard. Within the text, the SI units are shown in brackets. The values stated in each system are not exact equivalents; therefore, each system must be used independently of the other. Combining values from the two systems may result in nonconformance with the specification.

NOTE 1—Refer to Test Methods and Definitions A 370 for notes on significance of notched-bar impact testing.

<sup>1</sup> This specification is under the jurisdiction of ASTM Committee A01 on Steel, Stainless Steel and Related Alloys and is the direct responsibility of Subcommittee A01.22 on Steel Forgings and Wrought Fittings for Piping Applications and Bolting Materials for Piping and Special Purpose Applications.

Current edition approved October 1, 2004. Published October 2004. Originally approved in 1952. Last previous edition approved in 2004 as A 350/A 350M – 04.

<sup>2</sup> For ASME Boiler and Pressure Vessel Code applications see related Specification SA-350 in Section II of that Code.

### 2. Referenced Documents

#### 2.1 ASTM Standards:<sup>3</sup>

A 370 Test Methods and Definitions for Mechanical Testing of Steel Products

A 788 Specification for Steel Forgings, General Requirements

A 961 Specification for Common Requirements for Steel Flanges, Forged Fittings, Valves, and Parts for Piping Applications

#### 2.2 ASME Standards:

B 16.5 Steel Pipe Flanges and Flanged Fittings<sup>4</sup>

B 16.9 Factory-Made Wrought Steel Butt-Welding Fittings<sup>4</sup>

B 16.10 Face-to-Face and End-to-End Dimensions of Ferrous Valves<sup>4</sup>

B 16.11 Forged Steel Fittings, Socket-Welding and Threaded<sup>4</sup>

B 16.30 Unfired Pressure Vessel Flange Dimensions<sup>4</sup>

B 16.34 Valves-Flanged, Threaded, and Welding End<sup>4</sup>

B 16.47 Large Diameter Steel Flanges<sup>4</sup>

2.3 ASME Boiler and Pressure Vessel Code:  
Section IX Welding Qualifications<sup>2</sup>

#### 2.4 AWS Standards:

A 5.1 Mild Steel Covered Arc-Welding Electrodes<sup>5</sup>

A 5.5 Low-Alloy Steel Covered Arc-Welding Electrodes<sup>5</sup>

#### 2.5 API Standards:<sup>6</sup>

600 Steel Gate Valves with Flanged or Butt-Welding Ends

602 Compact Design Carbon Steel Gate Valves for Refinery Use

<sup>3</sup> For referenced ASTM standards, visit the ASTM website, [www.astm.org](http://www.astm.org), or contact ASTM Customer Service at [service@astm.org](mailto:service@astm.org). For *Annual Book of ASTM Standards* volume information, refer to the standard's Document Summary page on the ASTM website.

<sup>4</sup> Available from American Society of Mechanical Engineers (ASME), ASME International Headquarters, Three Park Ave., New York, NY 10016-5900.

<sup>5</sup> Available from The American Welding Society (AWS), 550 NW LeJeune Rd., Miami, FL 33126.

<sup>6</sup> Available from The American Petroleum Institute (API), 1220 L. St., NW, Washington, DC 20005.

\*A Summary of Changes section appears at the end of this standard.



## A 350/A 350M – 04a

## 605 Large Diameter Carbon Steel Flanges

## 3. Ordering Information

3.1 It is the purchaser's responsibility to specify in the purchase order information necessary to purchase the needed material. In addition to the ordering information guidelines in Specification A 961, orders should include the following information:

- 3.1.1 The number of test reports required (see Section 14).  
3.1.2 Additional requirements (see Table 1 footnotes).

## 4. General Requirements

4.1 Product furnished to this specification shall conform to the requirements of Specification A 961, including any supplementary requirements that are indicated in the purchase order. Failure to comply with the general requirements of Specification A 961 constitutes nonconformance with this specification. In case of conflict between the requirements of this specification and Specification A 961, this specification shall prevail.

## 5. Manufacture

5.1 *Melting Process*—The steel shall be produced by any of the following primary processes: open-hearth, basic oxygen, electric-furnace, or vacuum-induction melting (VIM). The primary melting may incorporate separate degassing or refining, and may be followed by secondary melting using electroslag remelting (ESR), or vacuum-arc remelting (VAR).

5.1.1 The steel shall be fully killed, fine-grain practice.

5.1.2 The molten steel may be vacuum treated prior to or during pouring of the ingot.

5.2 *Discard*—A sufficient discard shall be made to secure freedom from injurious piping and undue segregation.

5.3 *Forging Process*:

5.3.1 Material for forgings shall consist of ingots, or forged, rolled, or strandcast blooms, billets, slabs, or bars.

5.3.2 The finished product shall be a forging as defined in the Terminology section of Specification A 788.

5.3.3 Except for flanges of all types, hollow, cylindrically-shaped parts may be machined from rolled bar or seamless tubular materials provided that the axial length of the part is approximately parallel to the metal flow lines of the stock.

Other parts, excluding flanges of all types, may be machined from hot-rolled or forged bar up through and including NPS4. Elbows, return bends, tees, and header tees shall not be machined directly from bar stock.

5.4 *Heat Treatment*:

5.4.1 After hot working and before reheating for heat treatment, the forging shall be allowed to cool substantially below the transformation range.

5.4.2 Forgings of grades other than Grade LF787 shall be furnished in the normalized, or in the normalized and tempered, or in the quenched and tempered condition described by the following procedures:

5.4.2.1 *Normalize*—Heat to a temperature that produces an austenitic structure, holding sufficient time to attain uniform temperature throughout. Cool uniformly in still air.

5.4.2.2 *Normalize and Temper*—Subsequent to normalize, reheat to 1100 °F [590 °C] minimum, holding at temperature a minimum of 30 min/in. [30 min/25 mm] of maximum thickness, but in no case less than 30 min. Cool in still air.

5.4.2.3 *Quench and Temper*—The procedure for quenching shall consist of either (1) fully austenitizing the forgings followed by quenching in a suitable liquid medium or (2) using a multiple stage procedure whereby the forging is first fully austenitized and rapidly cooled, then reheated to partially reaustenitize, followed by quenching in a suitable liquid medium. All quenched forgings shall be tempered by reheating to a temperature between 1100 °F [590 °C] and the lower transformation temperature, holding at temperature a minimum of 30 min/in. [30 min/25 mm] of maximum thickness but in no case less than 30 min. Cool in still air.

5.4.3 Grade LF787 forgings shall be furnished in either the normalized-and-precipitation heat treated condition or in the quenched-and-precipitation heat treated condition. The heat treatment procedures shall be as follows:

5.4.3.1 *Normalized-and-Precipitation Heat Treated*—Heat to a temperature in the range from 1600 to 1725 °F [870 to 940 °C], hold at the temperature for a time sufficient to attain uniform temperature throughout, soak at the temperature for not less than ½ h, and remove from the furnace and cool in air. Subsequently, heat to a temperature in the range from 1000 to

TABLE 1 Chemical Requirements

Element	Composition, wt. %						
	Grade LF1	Grade LF2	Grade LF3	Grade LF5	Grade LF6	Grade LF9	Grade LF787
Carbon, max	0.30	0.30	0.20	0.30	0.22	0.20	0.07
Manganese	0.60–1.35	0.60–1.35	0.90 max	0.60–1.35	1.15–1.50	0.40–1.06	0.40–0.70
Phosphorus, max	0.035	0.035	0.035	0.035	0.025	0.035	0.025
Sulfur, max	0.040	0.040	0.040	0.040	0.025	0.040	0.025
Silicon <sup>A</sup>	0.15–0.30	0.15–0.30	0.20–0.35	0.20–0.35	0.15–0.30	...	0.40 max
Nickel	0.40 max <sup>B</sup>	0.40 max <sup>B</sup>	3.3–3.7	1.0–2.0	0.40 max <sup>B</sup>	1.60–2.24	0.70–1.00
Chromium	0.30 max <sup>B,C</sup>	0.30 max <sup>B,C</sup>	0.30 max <sup>C</sup>	0.30 max <sup>C</sup>	0.30 max <sup>B,C</sup>	0.30 max <sup>C</sup>	0.60–0.90
Molybdenum	0.12 max <sup>B,C</sup>	0.12 max <sup>B,C</sup>	0.12 max <sup>C</sup>	0.12 max <sup>C</sup>	0.12 max <sup>B,C</sup>	0.12 max <sup>C</sup>	0.15–0.25
Copper	0.40 max <sup>B</sup>	0.40 max <sup>B</sup>	0.40 max <sup>C</sup>	0.40 max <sup>C</sup>	0.40 max <sup>B</sup>	0.75–1.25	1.00–1.30
Columbium	0.02 max <sup>D</sup>	0.02 max <sup>D</sup>	0.02 max	0.02 max	0.02 max	0.02 max	0.02 min
Vanadium	0.08 max	0.08 max	0.03 max	0.03 max	0.04–0.11	0.03 max	0.03 max
Nitrogen	...	...	...	...	0.01–0.030	...	...

<sup>A</sup> When vacuum carbon-deoxidation is required by Supplementary Requirement S4, the silicon content shall be 0.12 % maximum.

<sup>B</sup> The sum of copper, nickel, chromium, vanadium and molybdenum shall not exceed 1.00 % on heat analysis.

<sup>C</sup> The sum of chromium and molybdenum shall not exceed 0.32 % on heat analysis.

<sup>D</sup> By agreement, the limit for columbium may be increased up to 0.05 % on heat analysis and 0.06 % on product analysis.



## A 350/A 350M – 04a

1200 °F [540 to 650 °C], soak at the temperature for not less than ½ h, and cool at any convenient rate.

5.4.3.2 *Quenched-and-Precipitation Heat Treated*—Heat to a temperature in the range from 1600 to 1725 °F [870 to 940 °C], hold at the temperature for a time sufficient to attain uniform temperature throughout, soak at the temperature for not less than ½ h and quench in a suitable liquid medium by immersion; reheat to a temperature in the range from 1000 to 1225 °F [540 to 665 °C], hold at the temperature for not less than ½ h, and cool at any convenient rate.

## 6. Chemical Composition

### 6.1 Heat Analysis:

6.1.1 A chemical heat analysis in accordance with Specification A 961 shall be made and conform to the requirements as to chemical composition prescribed in Table 1. Lead steels shall not be permitted.

### 6.2 Product Analysis:

6.2.1 The purchaser may make a product analysis on products supplied to this specification in accordance with Specification A 961.

## 7. Mechanical Properties

### 7.1 Tension Tests:

7.1.1 *Requirements*—The material shall conform to requirements for tensile properties in Table 2.

7.1.1.1 The test specimen shall be obtained from a rough or finished forging, or prolongation thereof. For forgings under 10 000 lbs, at time of heat treatment, it may be obtained from separately forged test blanks from the same heat of steel as the production forgings. The test blank shall be reduced by forging in a manner similar to that for the products represented, and shall receive approximately the same hot working and reduction and the same heat treatment as the finished products

represented. The test material shall be treated in the same furnace at the same time as the forging it represents, subject to the requirements of 7.1.2.1.

7.1.1.2 The test specimen shall represent all forgings from the same heat and heat-treatment load whose maximum thicknesses do not exceed the thickness of the test forging or blank by more than ¼ in. [6 mm].

7.1.2 *Number of Tests*—One tension test at room temperature shall be made in accordance with 7.1.1.2 from each heat in each heat-treatment load.

7.1.2.1 If heat treatment is performed in either a continuous or a batch-type furnace controlled within  $\pm 25$  °F [ $\pm 14$  °C] of the required heat-treatment temperature and equipped with recording pyrometers so that complete records of heat treatment are available and if the same heat-treating cycles are used on the forgings represented by the tension test, then one tension test from each heat shall be required, instead of one tension test from each heat in each heat treatment load in accordance with 7.1.1.2.

7.1.3 *Test Locations and Orientations*—The test specimen shall be removed from the heaviest section of the forging or test blank, at locations described in 7.1.3.1, 7.1.3.2, 7.1.3.5 or as close to these locations as practical, subject to forging size and geometry.

7.1.3.1 For forgings or test blanks having a maximum heat-treated thickness,  $T$ , of 2 in. [50 mm] or less, the longitudinal axis of the test specimen shall be taken at mid-thickness and its mid-length shall be at least 2 in. [50 mm] from a second heat treated surface, exclusive of the  $T$  dimension surfaces. (This is normally referred to as ½  $T$  by 2 in. [50 mm]).

7.1.3.2 For forgings or test blanks having a maximum heat-treated thickness,  $T$ , greater than 2 in. [50 mm], the central axis of the test specimen shall be taken at least ¼  $T$  from the

TABLE 2 Tensile Properties at Room Temperature<sup>A</sup>

	Grades							
	LF1 and LF5 Class 1	LF2 Classes 1 and 2	LF3 Classes 1 and 2 LF5 Class 2	LF6		LF9	LF787	
				Class 1	Classes 2 and 3		Class 2	Class 3
Tensile strength, ksi [MPa]	60–85 [415–585]	70–95 [485–655]	70–95 [485–655]	66–91 [455–630]	75–100 [515–690]	63–88 [435–605]	65–85 [450–585]	75–95 [515–655]
Yield strength, min, ksi [MPa] <sup>B,C</sup>	30 [205]	36 [250]	37.5 [260]	52 [360]	60 [415]	46 [315]	55 [380]	65 [450]
Elongation:								
Standard round specimen, or small proportional specimen, min % in	25	22	22	22	20	25	20	20
4D gage length								
Strip specimen for wall thickness 5/16 in. [7.94 mm] and over and for all small sizes tested in full section; min % in 2 in. [50 mm]	28	30	30	30	28	28	28	28
Equation for calculating min elongation for strip specimens thinner than 5/16 in. [7.94 mm]; min % in 2 in. [50 mm] $t$ = actual thickness in inches	48t + 13	48t + 15	48t + 15	48t + 15	48t + 13	48t + 13	48t + 13	48t + 13
Reduction of area, min, %	38	30	35	40	40	38	45	45

<sup>A</sup> See 7.3 for hardness tests.

<sup>B</sup> Determined by either the 0.2 % offset method or the 0.5 % extension under load method.

<sup>C</sup> For round specimens only.



## A 350/A 350M – 04a

nearest heat-treated surface and at least  $T$  or 4 in. [100 mm], whichever is less, from any second heat-treated surface. For quenched and tempered forgings, the midlength of the test specimen shall be at least  $T$  from any second heat-treated surface. See Fig. 1 for test specimen location in separately forged test blanks for quenched and tempered forgings.

**7.1.3.3 Metal Buffers**—The required distances from heat treated surfaces may be obtained with metal buffers instead of integral expansions. Buffer material may be carbon or low alloy steel, and shall be joined to the forging with a partial penetration weld that seals the buffered surface. Specimens shall be located at  $\frac{1}{2}$  in. [13 mm] minimum from the buffered surface of the forging. Buffers shall be removed and the welded areas subjected to magnetic particle test to assure freedom from cracks unless the welded areas are completely removed by subsequent machining.

**7.1.3.4** The test specimen shall have its longitudinal axis located parallel to the direction of major working of the forging or test blank.

**7.1.3.5** With prior purchaser approval, tests may be taken at a depth ( $t$ ) corresponding to the distance from the area of significant loading to the nearest heat treated surface and at least twice this distance ( $2t$ ) from any second surface. However, the test depth shall not be nearer to one treated surface than  $\frac{3}{4}$  in. [19 mm] and to the second treated surface than  $1\frac{1}{2}$  in. [38 mm]. This method of test location would normally apply to contour-forged parts, or parts with thick cross-sectional areas where  $\frac{1}{4} T \times T$  testing (7.1.3.2) is not practical. Sketches showing the exact test locations shall be approved by the purchaser when this method is used.

**7.1.4 Test Method**—Testing shall be performed in accordance with Test Methods and Definitions A 370. The test

specimen shall be as large as is practicable and shall be machined to the form and dimensions of Fig. 5 of Test Methods and Definitions A 370. When seamless tubular materials are used, testing shall be performed on longitudinal specimens in accordance with Annex A2, Steel Tubular Products, of Test Methods and Definitions A 370.

### 7.2 Impact Test:

**7.2.1 Requirements**—The material shall conform to the requirements for impact properties in Table 3 when tested at the applicable standard temperature in Table 4 within the limits of 7.2.4.2 and 7.2.4.3. When subsize specimens are used, the impact energy values obtained shall conform to Table 5 at energy values proportional to standard size. Exceptions to this requirement are permissible when Supplementary Requirement S1 is specified by the purchaser. Impact tests may be made at temperatures different from those in Table 4, provided that the test temperature is at least as low as the intended service temperature, and that the forging is suitably marked to identify the reported test temperature.

**7.2.1.1** The test specimens shall be machined from material obtained as in 7.1.

**7.2.2 Number of Tests**—Three specimens shall constitute one test set. There shall be the same number of test sets as tension tests in 7.1.2.

**7.2.3 Test Locations and Orientations**—The test specimen shall be located and oriented as described in 7.1.3. The area under the notch of the impact test specimen shall be used to locate the specimen with respect to the second heat-treated surface. The base of the notch shall be perpendicular to the nearest heat-treated surface.

Tensile or impact test specimen  
(Impact test specimen shown in Fig. 1)

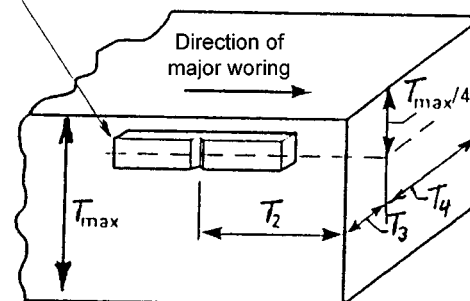

NOTE 1—For material with thickness  $T$  greater than 2 in. [50 mm],

$$T_2 = T_3 = T_4 \geq T_{\max}$$

where:

$T_{\max}$  = maximum heat treated thickness

**FIG. 1 Test Specimen Location for Quenched and Tempered Forgings**



## A 350/A 350M – 04a

**TABLE 3 Charpy V-Notch Energy Requirements for Standard Size [10 by 10 mm] Specimens**

Grade	Minimum Impact Energy Required for Average of Each Set of Three Specimens, ft·lb[J]	Minimum Impact Energy Permitted for One Specimen only of a Set, ft·lb[J]
LF1 and LF9	13 [18]	10 [14]
LF2, Class 1	15 [20]	12 [16]
LF3, Class 1	15 [20]	12 [16]
LF5 Class 1 and 2	15 [20]	12 [16]
LF787 Classes 2 and 3	15 [20]	12 [16]
LF6, Class 1	15 [20]	12 [16]
LF2, Class 2	20 [27]	15 [20]
LF3, Class 2	20 [27]	15 [20]
LF6, Classes 2 and 3	20 [27]	15 [20]

**TABLE 4 Standard Impact Test Temperature for Standard Size [10 by 10 mm] Specimens**

Grade	Test Temperature, °F [°C]
LF1	-20 [-29]
LF2 Class 1	-50 [-46]
LF2 Class 2	-0 [-18]
LF3, Classes 1 and 2	-150 [-101]
LF5, Classes 1 and 2	-75 [-59]
LF6, Classes 1 and 2	-60 [-51]
LF6, Class 3	0 [-18]
LF9	-100 [-73]
LF787, Class 2	-75 [-59]
LF787 Class 3	-100 [-73]

**TABLE 5 Minimum Equivalent Absorbed Energy ft·lb (J) for Various Specimen Sizes<sup>A</sup>**

Standard Size [10 by 10 mm]	¾ size [10 by 7.5 mm]	⅔ size [10 by 6.6 mm]	½ size [10 by 5 mm]	¼ size [10 by 3.3 mm]	¼ size [10 by 2.5 mm]
15 [20]	12 [16]	10 [14]	8 [11]	5 [7]	4 [6]
13 [18]	10 [14]	9 [12]	7 [10]	5 [7]	4 [6]
12 [16]	10 [14]	9 [12]	7 [10]	4 [6]	3 [5]
10 [14]	8 [11]	7 [10]	5 [7]	3 [5]	3 [5]

<sup>A</sup> Straight-line interpolation for intermediate values is permitted.

**7.2.4 Test Method**—The notched bar impact test shall be made in accordance with the procedure for the Charpy V-notch type test as described in Test Methods and Definitions A 370.

**7.2.4.1 Standard size specimens** shown in Fig. 11 of Test Methods and Definitions A 370 shall be used for the impact test. Where the material is of insufficient thickness, or the shape of the forging precludes standard size, the largest obtainable subsize specimen described in Test Methods and Definitions A 370 shall be used.

**7.2.4.2** Where subsize specimens are used and represent forged material with thicknesses equal to or greater than 0.394 in. [10 mm], and where the largest obtainable specimen has a width along the notch of at least 8 mm, such specimen shall be tested at the temperature in Table 4. Where the largest obtainable specimen has a width along the notch less than 8 mm, the temperature for testing shall be lower than the temperature in Table 4 by the amount shown in Table 6 for the actual specimen width tested.

**7.2.4.3** Where subsize specimens are used and represent forged material with thicknesses less than 0.394 in. [10 mm],

**TABLE 6 Charpy Impact Test Temperature Reduction Below Table 4 Test Temperature when the Subsize Charpy Impact Width along Notch is Less than 80% of the Forging Thickness**

Size of Bar	Thickness of the Material Represented (see 7.2.4.3), or Charpy, Impact Specimen Width Along the Notch <sup>A</sup> , in. [mm]	Temperature Reduction, °F [°C]
Standard	0.394 [10]	0 [0]
Standard	0.354 [9]	0 [0]
Standard	0.315 [8]	0 [0]
¾-size	0.295 [7.5]	5 [3]
¾-size	0.276 [7]	8 [5]
⅔-size	0.262 [6.67]	10 [6]
⅔-size	0.236 [6]	15 [8]
½-size	0.197 [5]	20 [11]
½-size	0.158 [4]	30 [17]
¼-size	0.131 [3.33]	35 [20]
¼-size	0.118 [3]	40 [22]
¼-size	0.099 [2.5]	50 [28]

<sup>A</sup> Straight-line interpolation for intermediate values is permitted.

and where the largest obtainable specimen has a width along the notch of at least 80 % of the forging thickness, the specimen shall be tested at the temperature in Table 4. Where the largest obtainable specimen has a width along the notch of less than 80 % of the material thickness, the temperature for testing shall be lower than the temperature in Table 4 by an amount equal to the difference (referring to Table 6) between the temperature reduction corresponding to the thickness of the material represented, and the temperature reduction corresponding to the specimen width actually tested.

### 7.3 Hardness Test:

**7.3.1** Except when only one forging is produced, a minimum of two forgings shall be hardness tested per batch or continuous run as defined in 7.1.2.1 to ensure that hardness of the forgings does not exceed 197 HB after heat treatment for mechanical properties. The hardness measurements shall be made in accordance with Test Methods and Definitions A 370. When only one forging is produced, it shall be hardness tested to ensure that it meets the 197 HB maximum of this specification. The purchaser may verify that this requirement has been met by testing at any location on the forging, provided that such testing does not render the forging useless.

## 8. Hydrostatic Test

**8.1** Forgings manufactured under this specification shall be capable of passing a hydrostatic test compatible with the rating of the finished item. Such tests shall be conducted by the manufacturer only when Supplementary Requirement S57 of Specification A 961 is specified.

## 9. Workmanship, Finish, and Appearance

**9.1** Forgings shall conform to the requirements of Specification A 961.

## 10. Retests

**10.1** If any test specimen shows flaws or defective machining, it may be discarded and another specimen substituted.

**A 350/A 350M – 04a****11. Rework and Retreatment**

11.1 If the results of the mechanical tests do not conform to the requirements specified, the manufacturer may reheat treat the forgings represented, and shall retest to the applicable requirements.

11.2 Individually tested forgings meeting all requirements shall be acceptable.

11.3 *Repair by Welding*—Weld repairs shall be permitted (see Supplementary Requirement S58 of Specification A 961) at the discretion of the manufacturer with the following limitations and requirements:

11.3.1 Repair by welding shall be made using welding procedures and welders qualified in accordance with ASME Section IX of the Code. The weld procedure qualification test shall also include impact tests of the weld metal and heat-affected zone. All impact test specimens shall have the longitudinal axis transverse to the weld and the base of the notch normal to the weld surface. Weld specimens shall have the notch in weld metal and heat-affected zone specimens shall have the notch in the heat-affected zone. The specimens shall be as large as permitted by the weldment thickness. Where full-size specimens can be obtained and where there is sufficient weldment thickness, the weld specimen shall be taken with one side of the specimen within  $\frac{1}{16}$  in. [1.6 mm] of the weld surface. Heat-affected zone impact test specimens shall be taken at the same depth and locations applicable to the forging in 7.1.3.1 and 7.1.3.2. When forgings are thermally treated after repair welding, the weld procedure test plate shall be subjected to the same thermal treatment. The mechanical properties of the weld procedure qualification test shall conform to Section 7.

11.3.2 Defects shall be completely removed by chipping or grinding to sound metal as verified by magnetic particle, or liquid penetrant inspection prior to welding.

11.3.3 For Grade LF1 forgings, and LF2 forgings that are to be only stress-relieved after repair welding, the weld metal shall be deposited using carbon steel electrodes E 7015, E 7016, or E 7018, complying with AWS A 5.1. For Grade LF2 forgings in all other conditions of post-weld heat treatment, the weld metal shall be deposited using low-alloy steel electrodes E 7015-A1; E 7016-A1, or E 7018-A1 complying with AWS 5.5; for Grade LF3 forgings the weld metal shall be deposited using low-alloy steel electrodes E 8016-C2 or E 8018-C2 complying with AWS A 5.5; for Grades LF5, LF9, and LF787 forgings, the weld metal shall be deposited using low-alloy steel electrodes E 8016-C1 or E 8018-C1 complying with AWS A 5.5. For Grade LF6, the electrodes shall be low-hydrogen, E-XX15, E-XX16, or E-XX18 complying with AWS A 5.1 or A 5.5, as applicable.

11.3.4 After repair welding, the area welded shall be completely free of defects as verified by magnetic particle or liquid penetrant inspection.

11.3.5 Forgings repair welded in the normalized, normalized and tempered, or the quenched and tempered conditions shall be stress-relieved after repair welding at 1100 °F [590 °C] minimum, but not higher than the temperature previously used for tempering the base metal of the same forging, or shall be reheat treated in accordance with 5.4.

11.3.6 When the purchaser specifies Supplementary Requirement S5, the same requirements shall apply to the weld procedure qualification tests.

11.3.7 Repair by welding shall not exceed 10 % of the surface area of the forging or  $33\frac{1}{3}$  % of the wall thickness of the finished forging, or  $\frac{3}{8}$  in. [9.5 mm], whichever is less, without prior approval of the purchaser.

11.3.8 When approval of the purchaser is obtained, the limitations set forth in 11.3.7 may be exceeded, but all other requirements of 11.3 shall apply.

**12. Inspection**

12.1 Inspection provisions of Specification A 961 shall apply.

**13. Rejection and Reheating**

13.1 Purchaser shall comply with provisions of Specification A 961.

**14. Certification**

14.1 Test reports are required and they shall include certification that all requirements of this specification have been met, and shall be traceable to the forging represented. The specification designation included on test reports shall include year of issue and revision letter, if any. The manufacturer shall provide the following where applicable:

14.1.1 Type heat treatment, Section 5,

14.1.2 Chemical analysis results, Section 6 (Table 1),

14.1.3 Product analysis results, 6.2 (Table 1),

14.1.4 Tensile property results, Section 7 (Table 2) report the yield strength and ultimate strength, in ksi [MPa], elongation and reduction in area, in percent,

14.1.5 Impact test results, 7.2 (Table 3, Table 4, Table 5, and Table 6),

14.1.6 Hardness results, 7.3.1,

14.1.7 Any supplementary testing required by the purchase order, and

14.1.8 If repaired by welding, letter W is to follow the ASTM designation.

**15. Product Marking**

15.1 In addition to the marking requirements of Specification A 961, manufacturer's name (see Note 2) or symbol shall be permanently marked on each forging.

NOTE 2—For purposes of identification marking, the manufacturer is considered the organization that certifies the piping component was manufactured, sampled, and tested in accordance with this specification and the results have been determined to meet the requirements of this specification.

15.1.1 If the forgings have been quenched and tempered or quenched-and-precipitation heat treated, the letters QT shall be stamped on the forgings following the ASTM designation.

15.1.2 Forgings repaired by welding shall be marked with the letter W following the ASTM designation.

15.2 If identification stamps are objectionable and detrimental to the forging, and when so stated on the purchase order, the marks may be painted or stenciled on the forging, or stamped on a metal or plastic tag which shall be securely attached to the forging.





## A 350/A 350M – 04a

15.3 When test reports are required, additional marks shall be used as necessary to identify the part with the test report.

15.4 If the test temperature is other than the standard temperature specified in Table 4, the mark shall also include the suffix letter S to the grade and class and the test temperature. A prefix 0 to the test temperature shall indicate a less than 0 °F [-18 °C] value. For example, LF2S 0175 denotes a test temperature of -175 °F [-115 °C] for an LF2 part.

15.5 Parts meeting all requirements for more than one class may be marked with more than one class such as LF2 CL1/C12; LF5 CL1/CL2, and so forth.

15.6 *Bar Coding*—In addition to the requirements in 15.1, 15.2, 15.3, 15.4, and 15.5, bar coding is acceptable as a

supplemental identification method. The purchaser may specify in the order a specific bar coding system to be used. The bar coding system, if applied at the discretion of the supplier, should be consistent with one of the published industry standards for bar coding. If used on small parts, the bar code may be applied to the box or a substantially applied tag.

### 16. Keywords

16.1 carbon equivalent; pipe fittings, steel; piping applications; pressure containing parts; steel flanges; steel forgings, alloy; steel forgings, carbon; steel valves; temperature service applications, low

## SUPPLEMENTARY REQUIREMENTS

In addition to any supplementary requirements of Specification A 961, the following supplementary requirements shall apply only when specified by the purchaser in the order:

### S1. Other Impact Test Temperatures

S1.1 Impact test temperatures lower or higher than the standard temperature in Table 4 of this specification shall be used.

S1.1.1 When higher test temperatures are employed, the actual test temperature may not be higher than that given in Table S1.1.1.

S1.2 The test temperature shall be specified by the purchaser. When subsize specimens are used, the manufacturer shall adjust the test temperature in accordance with the size restrictions of 7.2.4.2 and 7.2.4.3.

S1.3 The forging shall be marked with the specified test temperature in accordance with 15.4. A lower temperature shall not be marked on the forging because of the use of subsize specimens.

S1.4 The test results shall comply with Table 3 for standard size specimens, and with Table 5 for subsize specimens.

### S2. Stress-Relieved Test Specimens

S2.1 The test specimens shall be stress relieved. Stress relieving shall be done after heat treatment in 5.4 and before machining the specimens from the heat-treated test material.

S2.2 The purchaser shall furnish the forging manufacturer with details of the stress-relief treatment desired.

### S3. Lateral Expansion

S3.1 Lateral expansion of the Charpy V-notch test in accordance with Section 25 of Test Methods and Definitions A 370 shall be measured and reported.

### S4. Vacuum Carbon-Deoxidized Steels

S4.1 Material made to Grades LF1, LF2, LF3, LF5, and LF9 shall be vacuum carbon-deoxidized, in which case the silicon content shall be 0.12 % maximum. The test report shall indicate that the steel was vacuum carbon-deoxidized.

### S5. Special Impact Test Requirements for Flanges (Note S5.1)

S5.1 Charpy test specimens shall be cut from an actual flange representing each size, heat, and heat-treatment lot. If more than one size flange is represented by the same heat and heat-treatment lot, the maximum size flange shall be considered representative.

S5.2 The number, location, and orientation of the test specimens shall be stated on the order.

S5.3 The test results shall comply with Table 3 for standard size specimens, and with Table 5 for subsize specimens.

NOTE S5.1—These special requirements should be considered for services when the applied stresses approach the maximum permissible limits of the governing code, or the installation is subject to severe cyclic conditions (7000 or more cycles over the expected life of the installation), or both.

### S6. Carbon Equivalent

S6.1 The maximum carbon equivalent based on heat analysis shall be as shown in Table S6.1.

S6.2 Determine the carbon equivalent (CE) as follows:

$$CE = C + Mn/6 + (Cr + Mo + V)/5 + (Ni + Cu)/15$$

S6.3 A lower maximum carbon equivalent may be agreed upon between the supplier and the purchaser.

TABLE S1.1.1 Maximum Supplemental Test Temperatures

Grade	Maximum Test Temperature, °F [°C]
LF1	-10 [-23]
LF2, Class 1	-35 [-37]
LF3, Classes 1 and 2	-125 [-87]
LF5, Classes 1 and 2	-60 [-51]
LF6, Classes 1 and 2	-40 [-40]
LF9	-80 [-62]
LF787, Class 2	-60 [-51]
LF787, Class 3	-80 [-62]
LF2 Class 2	+10 [-12]
LF6 Class 3	+10 [-12]



## A 350/A 350M – 04a

**TABLE S6.1 Maximum Carbon Equivalent Value**

Grade	Max.Thickness Less Than or Equal to 2 in.	Max. Thickness Greater Than 2 in.
LF1	0.45	0.46
LF2 CL1 and CL2	0.47	0.48
LF6 CL1	0.45	0.46
LF6 CL2	0.47	0.48

### SUMMARY OF CHANGES

Committee A01 has identified the location of selected changes to this specification since the last issue, A 350/A 350M – 04, that may impact the use of this specification. (Approved October 1, 2004)

(I) Deleted paragraph 6.1.2 and revised Sections 3 and 14.

Committee A01 has identified the location of selected changes to this specification since the last issue, A 350/A 350M – 02b, that may impact the use of this specification. (Approved March 1, 2004)

(I) Revised Grades LF1 and LF2 in Table 1 to allow higher Cb by agreement.

*ASTM International takes no position respecting the validity of any patent rights asserted in connection with any item mentioned in this standard. Users of this standard are expressly advised that determination of the validity of any such patent rights, and the risk of infringement of such rights, are entirely their own responsibility.*

*This standard is subject to revision at any time by the responsible technical committee and must be reviewed every five years and if not revised, either reapproved or withdrawn. Your comments are invited either for revision of this standard or for additional standards and should be addressed to ASTM International Headquarters. Your comments will receive careful consideration at a meeting of the responsible technical committee, which you may attend. If you feel that your comments have not received a fair hearing you should make your views known to the ASTM Committee on Standards, at the address shown below.*

*This standard is copyrighted by ASTM International, 100 Barr Harbor Drive, PO Box C700, West Conshohocken, PA 19428-2959, United States. Individual reprints (single or multiple copies) of this standard may be obtained by contacting ASTM at the above address or at 610-832-9585 (phone), 610-832-9555 (fax), or service@astm.org (e-mail); or through the ASTM website (www.astm.org).*

КОНСТРУКЦИОННЫЕ СТАЛИ ДЛЯ ОФШОРНОГО



И НАЗЕМНОГО СТРОИТЕЛЬСТВА

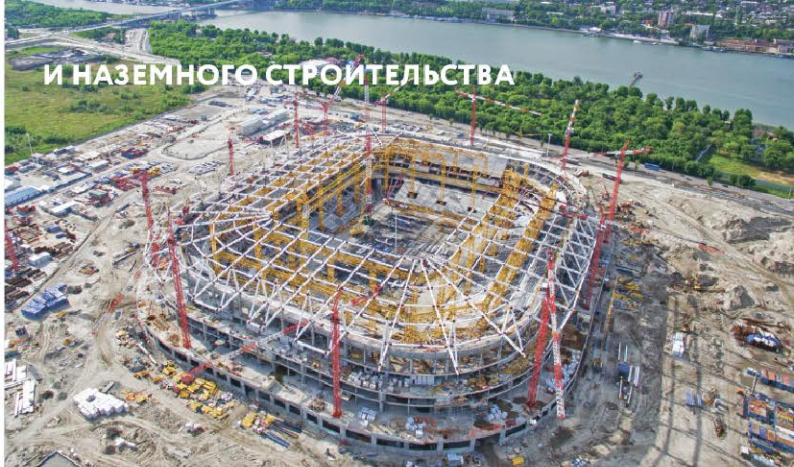

КОМПЛЕКСНЫЕ ПОСТАВКИ  
НА ПРЕДПРИЯТИЯ ПИЩЕВОЙ  
ПРОМЫШЛЕННОСТИ

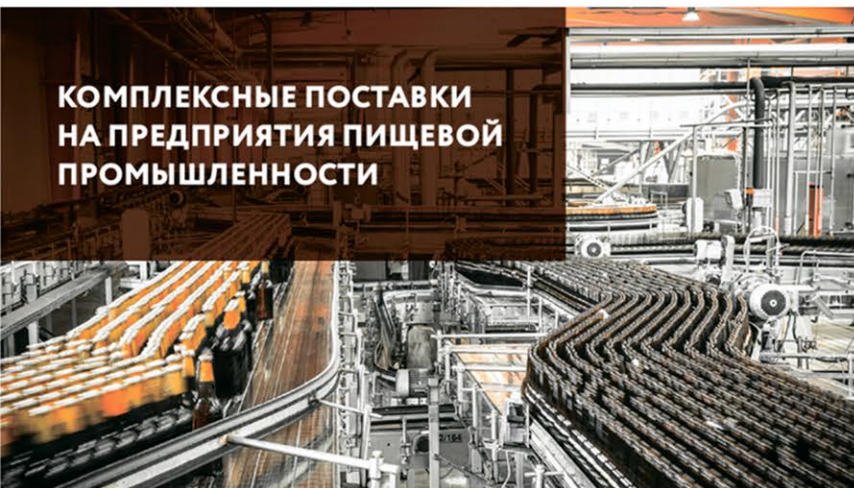

КОМПЛЕКСНЫЕ ПОСТАВКИ НА ОЛИМПИАДУ  
2014 В СОЧИ И ЧЕМПИОНАТ МИРА  
ПО ФУТБОЛУ 2018



КОМПЛЕКСНЫЕ ПОСТАВКИ  
ДЛЯ СТРОИТЕЛЬСТВА  
С НУЛЯ НА МАСШТАБНЫЕ  
**ПРОЕКТЫ**

В КОМПАНИИ  
РАБОТАЮТ  
БОЛЕЕ

**300**

ЧЕЛОВЕК

ЭНЕРГЕТИКА  
И СПЕЦИАЛЬНЫЕ ЗАКАЗЫ



- Новатэк
- Ямал СПГ
- ЩекиноАзот
- Акрон
- ЕвроХим
- Сибур
- Лукойл
- Росатом
- СПГ в Калининградской области
- Высоцкий СПГ
- Курская АЭС
- АЭС Руппур в Бангладеше
- Балаковская АЭС
- И другие...

ТРУБЫ И ОБВЯЗКА ДЛЯ  
НЕФТЕХИМИЧЕСКОЙ И  
АТОМНОЙ ПРОМЫШЛЕННОСТИ



КРУПНЕЙШИЙ ИНТЕРНЕТ-МАГАЗИН НЕРЖАВЕЙКИ  
**RUSSTEELS.RU**

РАБОТАЕМ  
С 2000 ГОДА

**2000**

ЗА ВСЁ ВРЕМЯ МЫ  
ПОСТАВИЛИ БОЛЕЕ

**200000**

ТОНН НЕРЖАВЕЮЩЕГО МЕТАЛЛА

ПОСТАВКИ ЛИСТОВОГО МЕТАЛЛА  
И ТРУБ ДЛЯ МАШИНОСТРОЕНИЯ



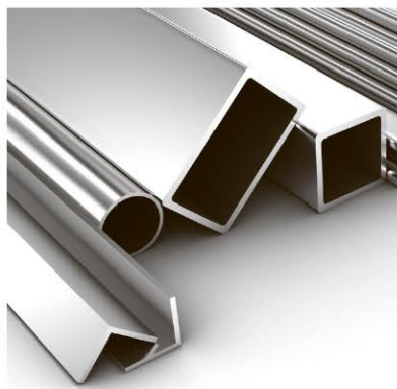

**ПОКУПАЙ  
БОЛЕЕ  
7000**  
ВИДОВ НЕРЖАВЕЙКИ  
ОНЛАЙН НА [RUSSTEELS.RU](http://RUSSTEELS.RU)



**Специальные  
Стали и Сплавы**

**E-MAIL: [INFO@RUSSTEELS.RU](mailto:INFO@RUSSTEELS.RU)  
[RUSSTEELS.RU](http://RUSSTEELS.RU)**

**Щелково**, +7 (495) 775-55-22  
ул. Заводская, д. 14Б, пом.17

**Челябинск**, +7 (351) 242-01-02  
пр-т Победы, д. 158, офис 407

**Санкт-Петербург**, +7 (812) 454-21-54  
пр-т Обуховской обороны, д. 112, литера И, БЦ "ВАНТ", офис 235

**Воронеж**, +7 (473) 300-38-88  
ул. Солнечная, 10Б, БК "Крепез", офис 210

**Краснодар**, +7 (861) 205-00-10  
Ростовское шоссе, д. 14/2, офис 306

**Самара**, +7 (846) 300-44-54  
Заводское шоссе, д. 111, офис 452

**Нижний Новгород**, +7 (831) 260-12-22  
ул. Варварская, д. 32, литера Д, офис 301

**Пятигорск**, +7 (8793) 31-78-22  
Черкесское шоссе, д. 11

